

FIRST® - Progesterone VGS R

Progesterone Vaginal Suppository USP Compounding Kit

FOR PRESCRIPTION COMPOUNDING ONLY

DESCRIPTION

Each FIRST® - Progesterone VGS Compounding Kit is comprised of micronized progesterone USP powder and fatty acid base (hard fat NF).* The progesterone contained in this product is derived from soy. FIRST® - Progesterone VGS Compounding Kits also contains the following components necessary to prepare 30 suppositories: 30-unit suppository mold w/caps, stirrer, suppository filling tool, guide plate, and 30-unit suppository mold protective cover w/suppository dispensing tool attached.

How Supplied and Compounding Directions

Size	100 mg	200 mg
NDC#	65628-062-01	65628-063-01
Progesterone USP	3.0 g	6.0 g
Fatty Acid Base (Hard Fat NF)	66.0 g	63.0 g

TO THE PHARMACIST

When compounding:

- Use personal protective equipment as required.
- Avoid inhalation and contact with skin, eyes, and clothing.
- Avoid interruption while compounding to limit exposure.

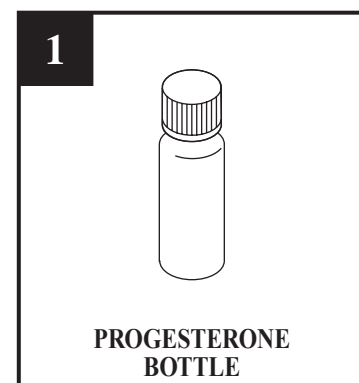
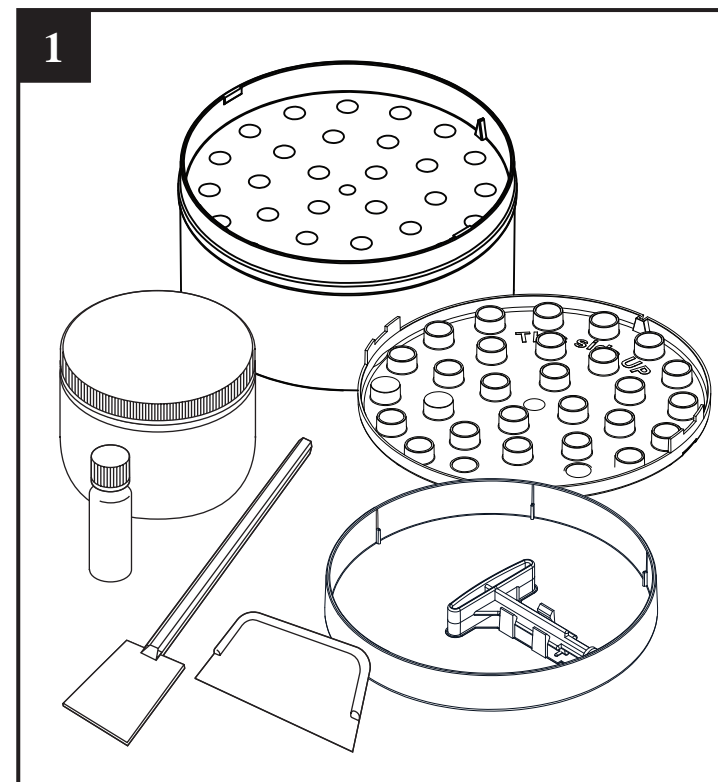

1. FIRST® - Progesterone VGS Compounding Kits contain preweighed progesterone powder and pre-weighed fatty acid base in sufficient quantity for the pharmacist to prepare 30 vaginal suppositories. **Important** - Prior to compounding and dispensing, read the instructions completely and make certain that all the components are present. **Place all components aside until instructed to use in each step.**

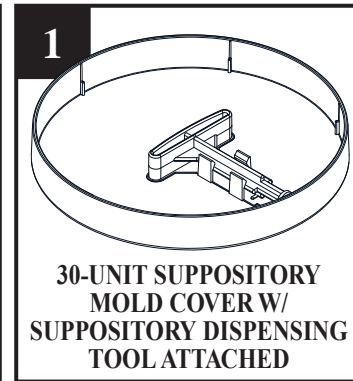
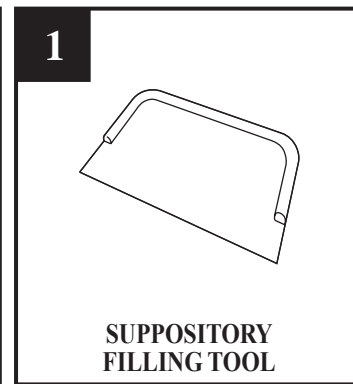
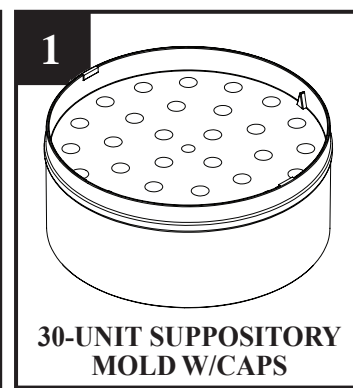
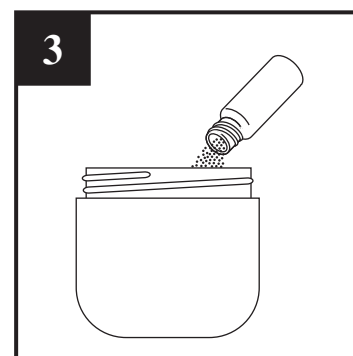
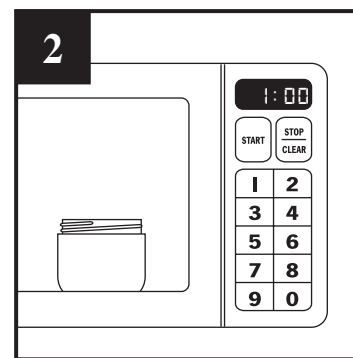
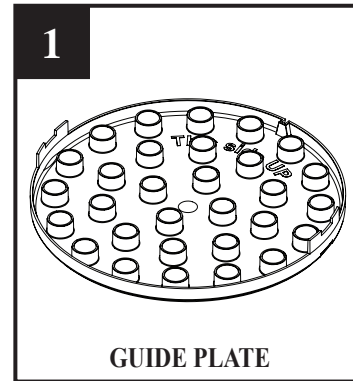
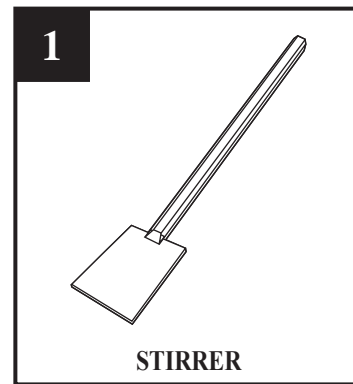
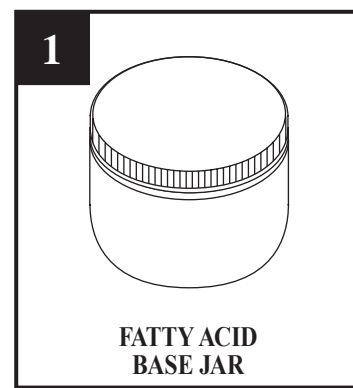

2. Remove the cap from jar containing fatty acid base and melt the base placing the jar in a standard microwave. **Melting times may vary depending on the type of microwave used.** It is recommended that you initially set the timer for 1 minute and check to see if the base has melted. If it has not, return the jar of base to the microwave for 15 second increments until the base is **completely** melted. Generally, the fatty acid base will completely melt between 1 and 3 minutes. **DO NOT OVERHEAT.**

3. **With your finger**, tap the top and bottom of the bottle to loosen the progesterone powder and remove the cap. Empty the contents of the bottle into the jar containing the melted fatty acid base. It is recommended that you also tap the bottom and sides of the bottle while emptying. Recap bottle when finished emptying. The appropriate quantity of progesterone powder has been packaged in the bottle to deliver enough progesterone required for each suppository.

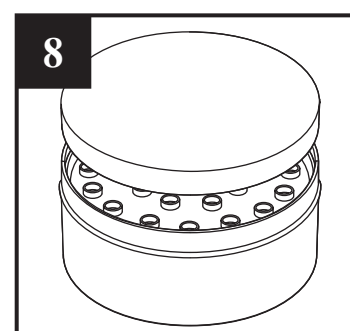
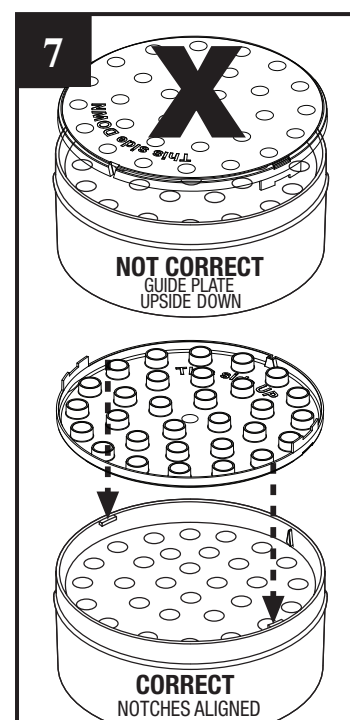
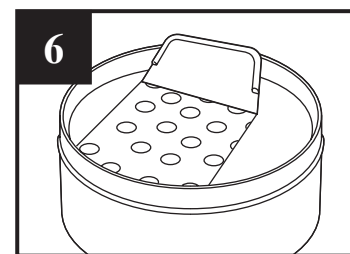
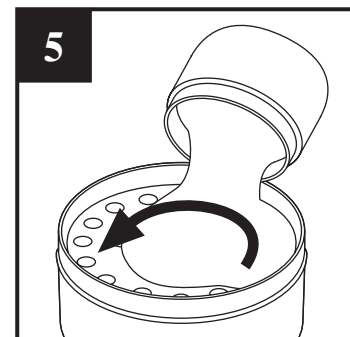
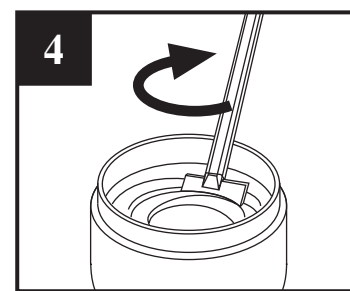

4. Using the stirrer provided, carefully stir the progesterone powder in the melted fatty acid base until an homogeneous suspension is apparent (30 to 60 seconds). **Be careful not to stir so vigorously as to spill the suspension outside the jar.**

5. With an even flow, carefully pour the entire suspension from the jar onto the 30-unit suppository mold in a circular motion filling each of the 30 suppository cavities.

6. Using the suppository filling tool provided, spread the suspension evenly over the suppository cavities until all the cavities are completely filled.

7. Place the provided guide plate onto the mold with "this side up" facing upward. If "this side down" is seen, remove and turn over.

IMPORTANT: **Make certain the notches and alignment key on the guide plate align with notches and alignment key on suppository mold.**

This will ensure that the 30 suppository cavities are aligned with the raised holes in the guide plate. Gently push the guide plate down to lock it in place. It is important that you fit the guide plate properly in order for your patient to dispense the suppositories easily.

8. Place the provided cover with attached suppository dispensing tool onto the suppository mold. **After compounding, do not hold suppository mold by cover.** Store entire unit at refrigerated temperature for at least 15 minutes in order to allow the suppositories to solidify. Visually check the suppositories for solidification before dispensing the entire unit to your patient.

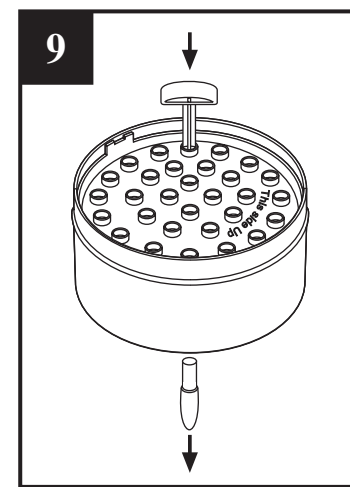

9. Make certain to instruct your patient how to dispense each suppository for daily use. Using the suppository dispensing tool attached to the mold cover, place the tip of the tool into the guide plate and with a firm force push the suppository through. Your patient should refrigerate the mold at least 1 hour for total solidification before dispensing the first suppository for use. **Important: Be sure to instruct your patient to remove the red suppository cap from the suppository before inserting each suppository.**

Dispose of waste in accordance with all applicable state/federal laws and regulations.

Prior to compounding, store FIRST® - Progesterone VGS Compounding Kits at room temperature between 15°-30°C (59°-86°F) [see USP]. Store the compounded suppositories in the 30-unit suppository mold in the refrigerator (2°-8°C [36°-46°F]). The preparation of vaginal suppositories using FIRST® - Progesterone VGS Compounding Kit complies with the requirements of USP, and as such, compounded suppositories made using FIRST® - Progesterone VGS Compounding Kit can be used for up to ninety days after the day on which they were compounded.

When compounded and dispensed according to the instructions, average suppository weight has been found to be 2.3 grams and contain 90-110% of progesterone as labeled.**

The suppository mold and its accessories contained in this kit meet the requirements for USP Cytotoxicity Test, as well as Class VI Tests for plastic containers.**

Instruct patient as follows:

- For vaginal use only
- Do not take orally
- Do not insert in urinary opening or anus
- Avoid contact with eyes
- Keep out of reach of children
- Protect from light
- Keep container tightly closed
- Store suppositories in the mold, in the refrigerator
- Remove red caps from suppositories prior to use

* Certificate of analysis on file
** Data and documentation on file

R only

Revised: March 2020

Manufactured for:
azurity™
pharmaceuticals

Wilmington, MA 01887 USA
www.azurity.com



REV 01